

REVISIONS					
REV.	DATE	ECN #	DESCRIPTION	BY	APPROVED

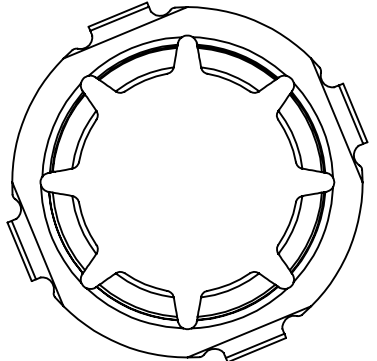

STEEL SPIN-GRIP NUT
PACKED IN BULK

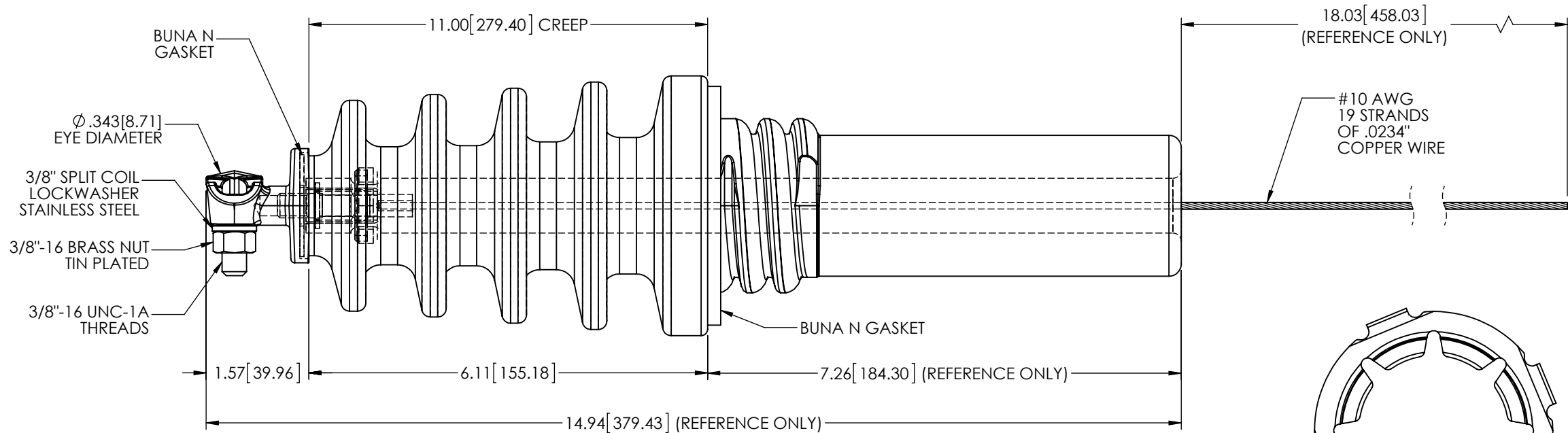
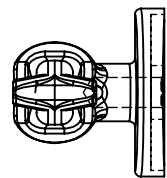
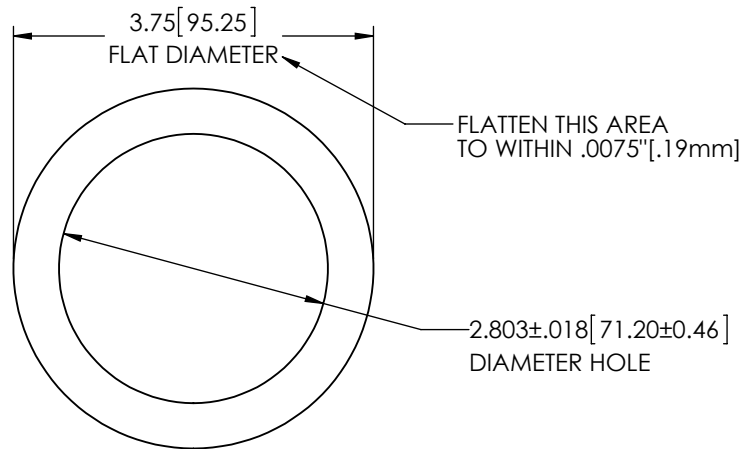

H.V. TANK HOLE DIMENSIONS

- NOTES:
- CAP INSTALLED TO 240 INCH POUNDS.
- PORCELAIN NOTES:
- GRAY GLAZE MUNSELL 5BG 7.0/0.4 TOLERANCE ±3% WITH NOTHING LESS THAN ±.03, UNLESS OTHERWISE NOTED ON DRAWING.
 - WET PROCESS ELECTRICAL PORCELAIN.

MATERIALS:

EYEBOLT - C95500 TIN-PLATED
H.V. CAP - C84400 TIN-PLATED

PROPRIETARY AND CONFIDENTIAL
THE INFORMATION CONTAINED IN THIS DRAWING IS THE SOLE PROPERTY OF H-J ENTERPRISES, INC. ANY REPRODUCTION IN PART OR AS A WHOLE WITHOUT THE WRITTEN PERMISSION OF H-J ENTERPRISES, INC. IS PROHIBITED.

TOLERANCES (EXCEPT AS NOTED)	
DECIMAL	+/- .032" / .8mm
FRACTIONAL	+/-
ANGULAR	+/- 2 Degrees



H - J ENTERPRISES, INC.
3010 HIGH RIDGE BLVD. HIGH RIDGE, MO. 63049 USA
PHONE 1-636-677-3421 FAX 1-636-376-1915

15 kV H.V. BUSHING ASSEMBLY

MATERIAL		SEE DRAWING	
CHK'D	NK	APP'D	01/22/14
DRAWN BY		DATE	DRAWING NO.
CLS		01/22/2014	AS1143-074
SCALE		N.T.S.	